

Specifications

Nominal Voltage	12V	
Nominal Capacity(20hr)	7AH	
Dimension	Length	151±2mm(5.94inch)
	Width	65±2mm(2.56inch)
	Height	94±2mm(3.7inch)
	Total Height	98±2mm(3.86inch)
Approx Weight	Approx. 2.08kg(+ -4%)	
Terminal Type	F1/F2	
container Material	ABS(UL-94HB)	
Internal Resistance	Approx. 18mΩ	
Rated Capacity	7AH	(20hr, 1.75V/cell,25°C/77°F)
	6.8AH	(10hr, 1.75V/cell,25°C/77°F)
	6.2AH	(5hr, 1.70V/cell,25°C/77°F)
	5.6AH	(3hr, 1.70V/cell,25°C/77°F)
	3.9AH	(1hr, 1.60V/cell,25°C/77°F)
Max. Discharge Current	105A(5S)	
Nominal Operating Temp. Range	25±3°C (77±5°F)	
Cycle Use	Charge Current Less Than 0.25CA	
	14.1V~14.7V@25°C(77°F)Temp. Coefficient -30mV/°C	
Floating Use	13.5V~13.8V@25°C(77°F)Temp. Coefficient -20mV/°C	
Capacity affected by Temperature	40°C	103%
	25°C	100%
	0°C	86%
	-15°C	65%
Self-discharge	3 month	Remaining capacity: 91%
	6 month	Remaining capacity:82%
	12month	Remaining capacity:65%

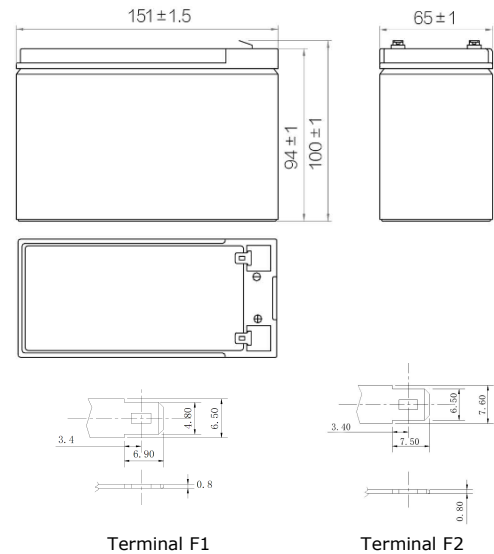

Dimensions



Constant Power Discharge at 25°C(77°F)

F.V/Time	5min	10min	15min	30min	1h	2h	3h	4h	5h	6h	10h	20h
1.80V/cell	41.7	27.6	22.3	14.8	8.61	4.72	3.40	2.79	2.73	1.95	1.28	0.68
1.75V/cell	43.8	29.6	23.6	15.2	8.74	4.80	3.44	2.81	2.74	2.00	1.30	0.69
1.70V/cell	46.6	30.7	24.8	15.6	8.90	4.86	3.45	2.83	2.74	2.03	1.31	0.71
1.67V/cell	47.6	31.7	25.4	15.7	8.92	4.87	3.45	2.83	2.76	2.07	1.32	0.72
1.60V/cell	48.9	31.9	25.8	15.9	8.95	4.91	3.47	2.84	2.78	2.11	1.34	0.74

Constant Current Discharge at 25°C(77°F)

F.V/Time	5min	10min	15min	30min	1h	2h	3h	4h	5h	6h	10h	20h
1.80V/cell	20.7	13.5	11.1	7.22	3.91	2.25	1.74	1.40	1.11	1.00	0.65	0.36
1.75V/cell	22.4	14.7	11.7	7.41	4.10	2.34	1.78	1.44	1.18	1.02	0.66	0.36
1.70V/cell	24.1	15.9	12.3	7.60	4.23	2.40	1.82	1.47	1.21	1.04	0.68	0.36
1.67V/cell	25.7	17.1	12.9	7.79	4.32	2.43	1.90	1.53	1.24	1.07	0.69	0.37
1.60V/cell	27.4	18.3	13.5	7.98	4.37	2.54	1.96	1.57	1.29	1.09	0.70	0.37

Discharge Characteristics

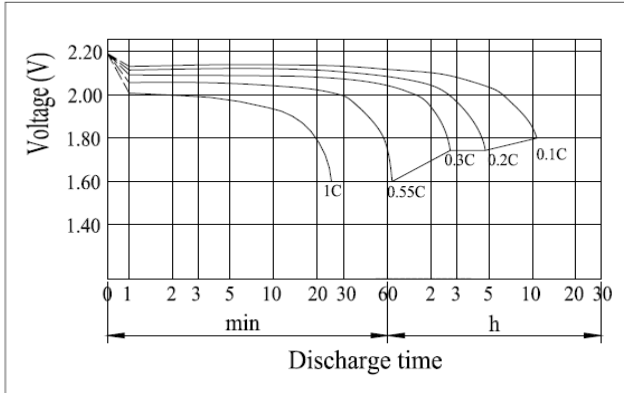

Float Charging Characteristics

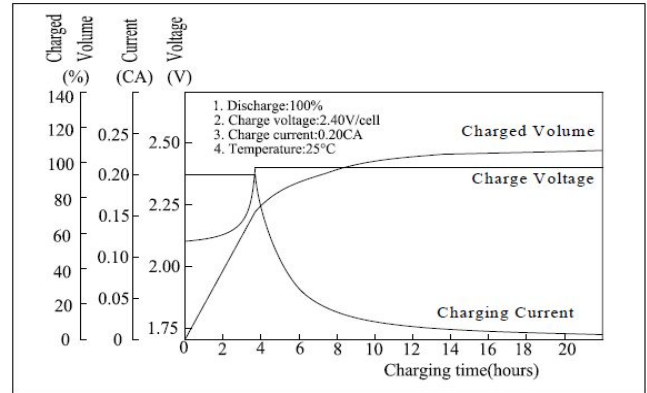

Floating Life on Temperature

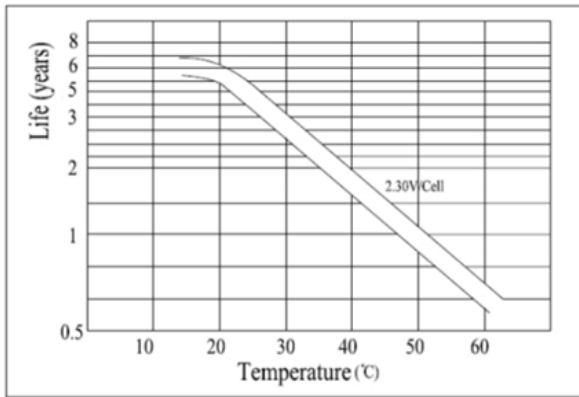

Self Discharge Characteristics (25°C (77°F))

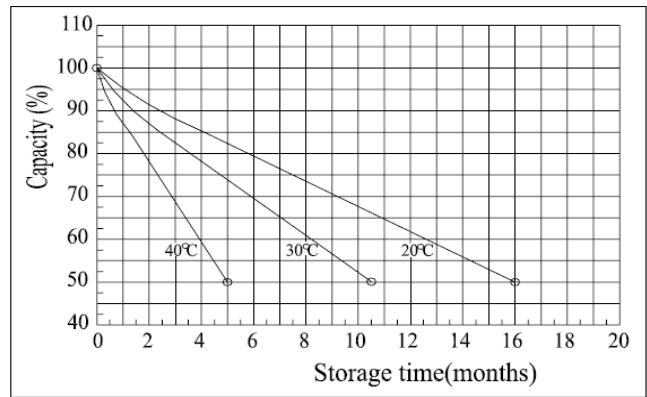

Temperature Effects in Relation to Battery Capacity

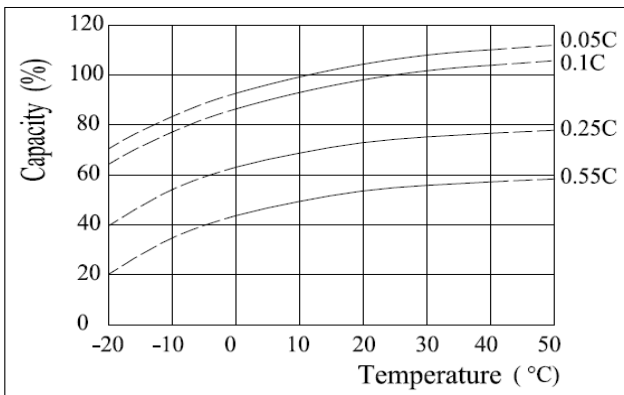

Cycle Life Relation to Depth of Discharge

